



COMPLETE STREETS COMMITTEE

AGENDA

DATE: September 12, 2023
TIME/PLACE: 7:30 AM - 9:00 AM
PRESENT: Chair Liz McDonald, Vice-Chair Barbara Guffin, Councilor Chip Lawrence, Police Chief Nate Goodman, Sally Walsh, Kim True, Andy Seymour, Phil Wagner, Greg Michaud, Adam Bliss
ABSENT:
GUESTS: Brett Richardson, FEDC

TOPIC	DISCUSSION	ACTION
I. Welcoming Comments (McDonald) (5 minutes)	<ul style="list-style-type: none">• Welcoming comments• Review Agenda	Informational only, no vote.
II. Minutes (McDonald) (5 minutes)	<ul style="list-style-type: none">• Motion to accept August 8, 2023 minutes as written.	Motion passed.
III. Town Wharf Parking (Bliss) (10 minutes)	<ul style="list-style-type: none">• Request to relocate the Harbor Master Parking Spot at the Town Wharf	TBD.
IV. Complete Streets Committee Workplan (McDonald) (20 minutes)	<ul style="list-style-type: none">• Review Workplan	Informational only, no vote.
V. Connect Freeport (Guffin) (10 minutes)	<ul style="list-style-type: none">• Route One South MUP Planning Grant• Land and Water Conservation Grant: Request for Grant Writer• General Updates, Other	Informational only, no vote.
VI. Lower Main Street Railroad Overpass Bridge (Bliss) (15 minutes)	<ul style="list-style-type: none">• Cost sharing proposal from Maine DOT for a 10-foot wide multi-use path alongside the new bridge.• Request for CSC to endorse and recommend the multi-use path to the Town Council.	TBD.



<p>VII. Varney Road Sidewalk (10 minutes) (FEDC)</p>	<ul style="list-style-type: none"> • Varney Road Senior Housing Project Proposal • Request for the CSC to support future construction of 800 feet of sidewalk along Varney Road from the Concord Brook Trail intersection to Lower Main Street 	<p>TBD.</p>
<p>VIII. Information Exchange/ Project Updates (15 minutes) (Bliss)</p>	<ul style="list-style-type: none"> • Downtown Vision Project Charters (Updates) <ul style="list-style-type: none"> ○ Momentum Grant Committee Representative ○ Pop-up Gardens ○ Parking Requirements Study ○ Wayfinding Signs ○ Bow and Main Intersection (on hold) • Maine DOT Project List Review 	<p>Informational only, no vote.</p>
<p>IX. Adjournment</p>	<ul style="list-style-type: none"> • The next meeting is October 10, 2023. • Motion to adjourn. 	<p>Motion passed.</p>



MINUTES

DATE: August 8, 2023
TIME/PLACE: 7:30 AM - 9:00 AM
PRESENT: Chair Liz McDonald, Adam Bliss, Greg Michaud, Sally Walsh, Police Chief Nate Goodman, Kim True
PRESENT via Zoom: Councilor Chip Lawrence, Barbara Guffin
ABSENT: Andy Seymour, Phil Wagner
GUESTS: Councilor Dan Piltch, Brett Richardson of FEDC

TOPIC	DISCUSSION	ACTION
I. Welcome, Agenda, Minutes	<ul style="list-style-type: none"> • Agenda Reviewed • Motion to approve minutes of June 13, 2023 meeting with an edit to include scheduled date of Mallett Drive paving by Greg Michaud, seconded by Sally Walsh. All approved. 6 in favor, none opposed. 	Motion passed, 6-0
II. Pleasant Hill and Flying Point Road Intersection	<ul style="list-style-type: none"> • Resident brought this concern to CSC a few months ago. Police collected speed and traffic data. Speed is an issue as folks are driving 45 mph on both roads while the posted speed is 35 mph on Pleasant Hill Rd and 40 mph on Flying Point Rd. Sight visibility is also a concern. Adam shared screen of proposals: add a “Changes to traffic pattern” sign on Pleasant Hill Rd, then closer to the intersection, add a flashing “STOP sign ahead” sign, and then add a flashing STOP sign at the intersection. Before we put these signs up, we will post an electronic board to inform drivers of “New STOP sign coming.” There was a suggestion to reduce the speed limit to 25 mph just before the STOP sign. Motion to accept these sign recommendations by Greg Michaud, seconded by Chip Lawrence. All approved 7 in favor, none opposed. • After vote, there was a question about sight lines, angle of turn and pole that is blocking visibility. We will continue to monitor this intersection to ensure all is working properly. 	Motion passed, 7-0
III. Transit-Oriented District TIF Study (FEDC)	<p>Brett Richardson from FEDC presented a proposal for a Transit-Oriented Development corridor along Lower Main Street. This idea came from the Sewer District discussion of high connection fees and a plan to make infrastructure upgrades. The map presented at the meeting shows the properties that could be affected. Consultants Bernstein Shur have been hired to do the tax shift analysis and determine the impact of tax dollars. CSC will create a list of prioritized suggestions for pedestrian crossing, traffic signals, and more. The Committee then discussed TIF funding mechanisms and dollars brought in as there is a need to generate revenues for the Downtown work.</p>	



<p>IV. Downtown Village Streetscaping</p>	<ul style="list-style-type: none"> • Councilor Dan Piltch thanked the Committee for all the work done related to Complete Streets as well as the Downtown Visioning Plan. A demonstration project is being proposed whereby a portion of the Bow and Main Street Intersection would be painted such that it narrows Main Street to allow for some shops, accessible parking, perhaps plantings, and other enhancements. This demonstration project is a less expensive way to get feedback about the viability of this proposal. The idea of adding additional Pop-up Gardens to Main Street will also be studied. Kim True volunteered to spearhead this project and to ensure that paths for bicyclists are sufficient. 	
<p>V. Connect Freeport</p>	<ul style="list-style-type: none"> • Barbara updated the Committee about Connect Freeport's wish to hire a contract position grant writer for the Land and Water Use Conservation Fund (LWCF) grant that is due June 30, 2024 deadline. Discussion revolved around presenting a case to the Town Council about what would be created, how it would be done, the likelihood of getting the grant, etc., to make a persuasive presentation to the Council. • About a year ago, we received grant funding from GPCOG to study the Route One South MUP and Landowner Outreach. This "interior segment" of the Freeport multi-use path and East Coast Greenway goes from Casco Bay YMCA to Pine Street. Adam and the Consultant from Toole Design recently walked the area and had some great ideas. The next step is to review GIS data and development and site plans of the properties. 	
<p>VI. Downtown Vision Project Charter Updates</p>	<ul style="list-style-type: none"> • Parking - RFP to go out for bid on buildout of surface parking. This project has overlap with CSC purview. • Mallett Drive MUP Design is waiting for MDOT info, and then we are confident that Adam will be able to write an RFP for the project. • EV charging stations are back to the drawing board as the Level 2 charger grant deadline has passed, and we were not awarded the Level 3 Charger grant. 	
<p>VII. Information Exchange</p>	<ul style="list-style-type: none"> • Freedom of Access Act (FOAA) says that three or more committee people discussing a town issue constitute a meeting. More to be discussed next time. • The Maine DOT Project List will be reviewed next time. • Phil Wagner, Barbara Guffin, and Elizabeth McDonald have terms expiring September 2023 and may renew. 	
<p>VIII. Adjournment</p>	<ul style="list-style-type: none"> • Motion to adjourn by Barbara Guffin, seconded by Sally Walsh, all approved, 6 in favor, none opposed. The next meeting is September 12, 2023 	<p>Motion passed, 6-0</p>

**TOWN WHARF, SOUTH FREEPORT
HARBOR MASTER PARKING SPOT
RELOCATION**

**PROPOSED
HARBOR
MASTER
PARKING SPOT**

**EXISTING HARBOR
MASTER PARKING SPOT**

**HOIST AND
LOADING / UNLOADING
AREA**

**HARBOR MASTER
BUILDING**



Date: 12/17/2021

Username: iflanders

Division: BRIDGE

Filename: ... \BRIDGE\MSTA002_Gen_Plan.dgn

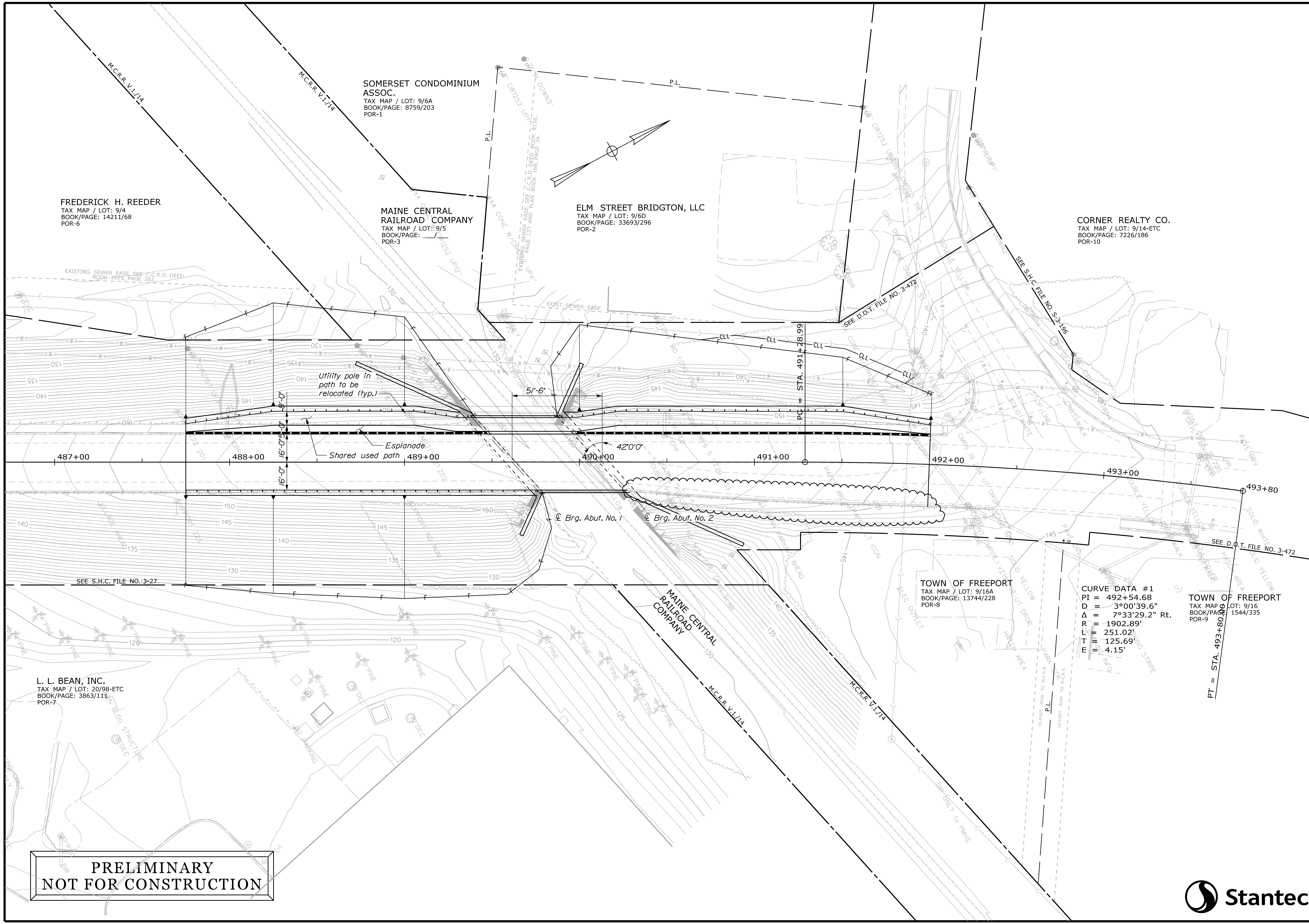

**PRELIMINARY
NOT FOR CONSTRUCTION**



STATE OF MAINE		DEPARTMENT OF TRANSPORTATION		STP-2123(400)		BRIDGE NO. 3172		WIN 21234.00		BRIDGE PLANS	
PROJ. MANAGER	A. LATHE	DATE	FEB 2022	BY	T.M.	SIGNATURE		P.E. NUMBER		DATE	
DESIGN DETAILED	LSF	DATE	FEB 2022	CHECKED	REVIEWED	DDT		REVISIONS 1			
DESIGNS DETAILED								REVISIONS 2			
REVISIONS 1								REVISIONS 3			
REVISIONS 2								REVISIONS 4			
REVISIONS 3								FIELD CHANGES			
REVISIONS 4											
RAILROAD CROSSING MAINE CENTRAL RAILROAD FREEPORT			CUMBERLAND COUNTY			GENERAL PLAN 8 FT SHARED USE PATH					
SHEET NUMBER											
2											
OF 52											

BRIDGE TYPICAL SECTIONS

Notes:

1. Girder sizes are shown conceptually and are not 100% to scale.
2. Shear studs will be used for both alternatives, though not shown on the 5' sidewalk section.

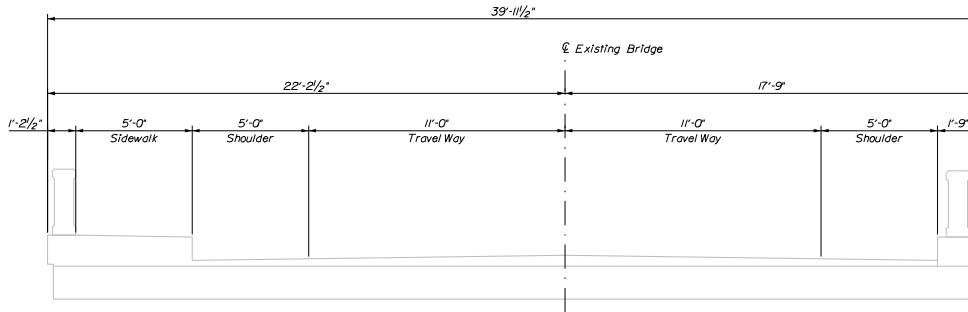

EXISTING TYPICAL SECTION

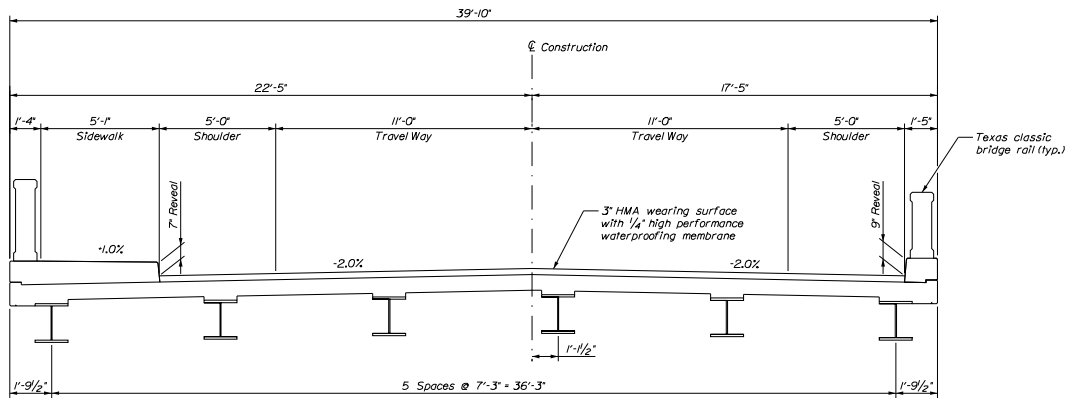

PROPOSED TYPICAL SECTION - 5 FT SIDEWALK

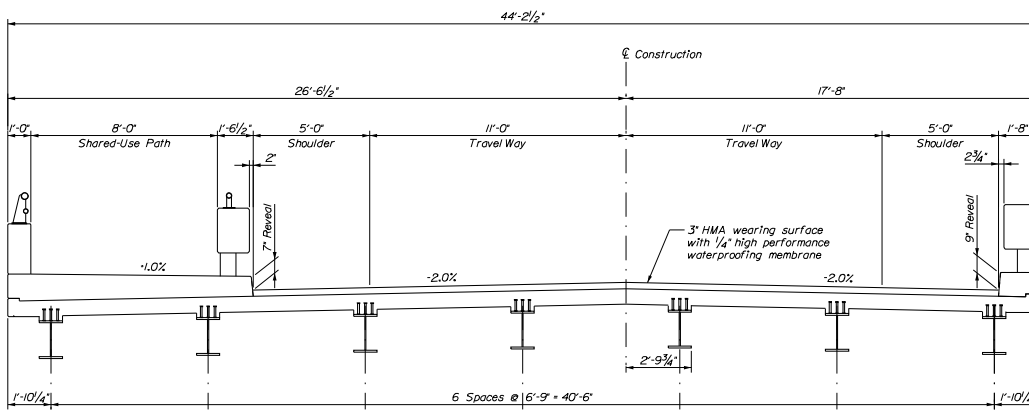

PROPOSED TYPICAL SECTION - SHARED USE PATH

ASSUMED APPROACH TYPICAL SECTIONS

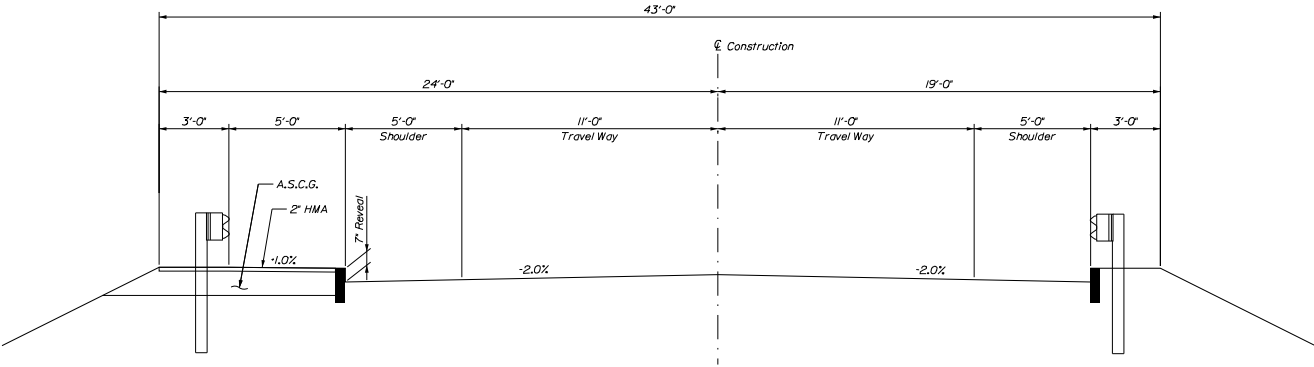

PROPOSED TYPICAL SECTION - 5'-0" SIDEWALK

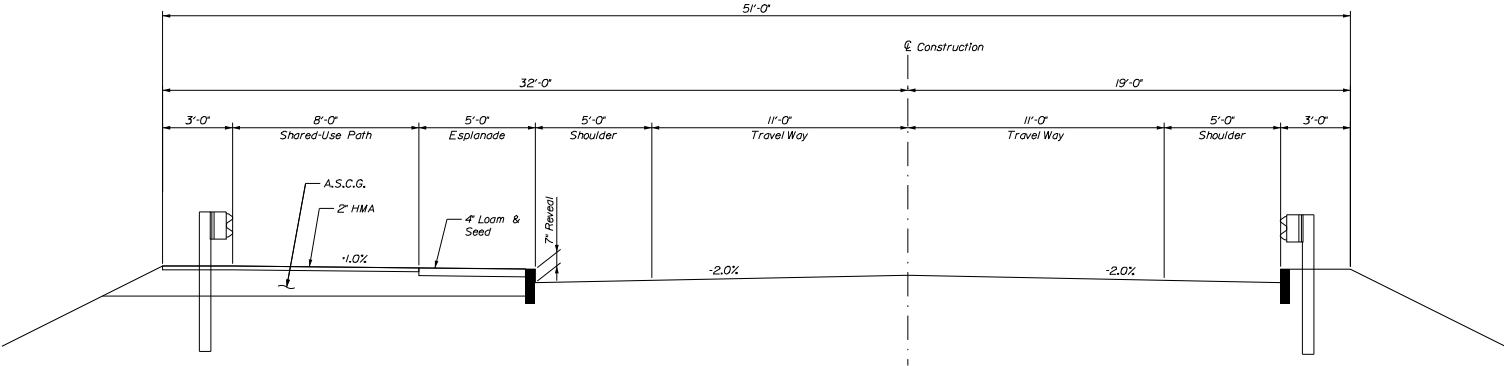

PROPOSED TYPICAL SECTION - 8'-0" SHARED USE PATH

The Project



42 Units of Senior Housing



Accessible



Affordable



Close to Amenities

(Shopping, Banking, Dining, & Highways)



Fixed-Route Transportation

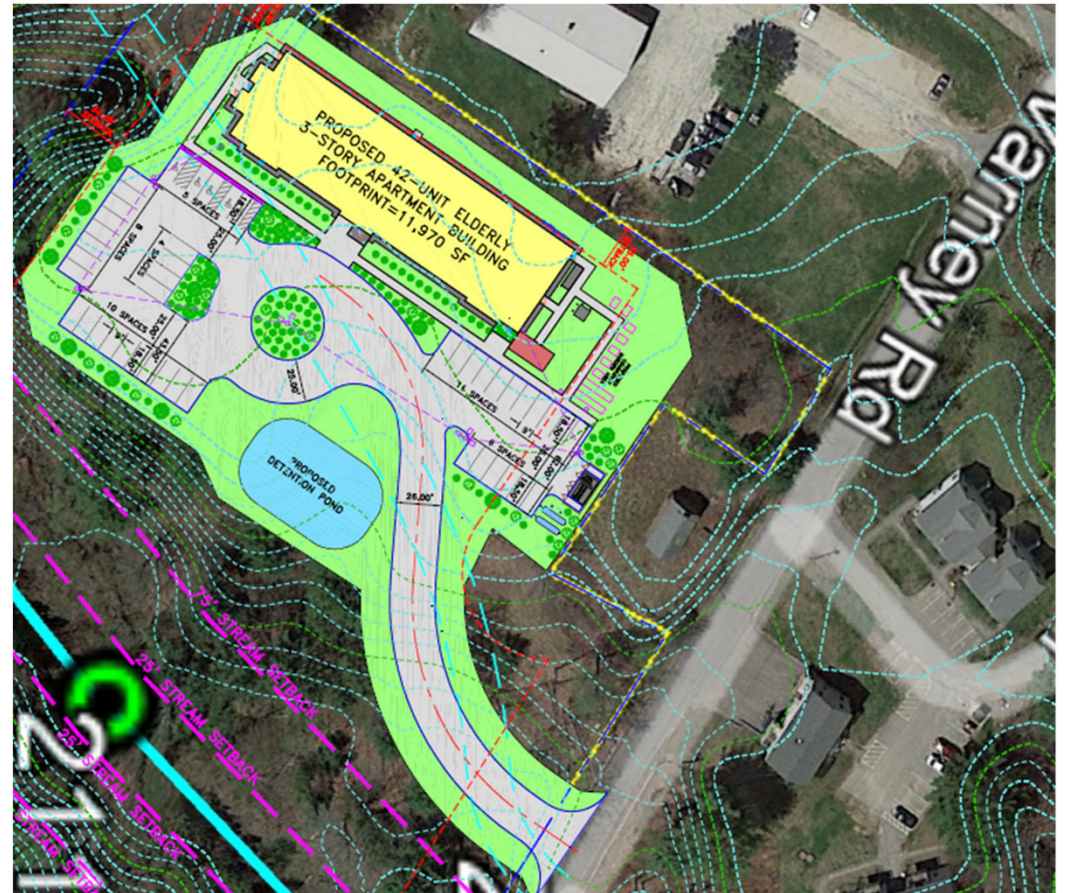

Freeport Downtown Momentum Grant Program



Momentum deploys grant funds to empower residents and local organizations to execute high-visibility projects that enhance the experience of residents and visitors and add vitality to the Downtown.



Momentum Activates Public Spaces

Momentum unleashes the creativity of residents and community organizations to help design the future of Freeport's Downtown with new amenities and installations that add beauty and fun activities.

Available Funding



Typical grants are \$2,500 to \$5,000



\$40,000 total is available



Matching contributions encouraged



Eligible Projects

Public art installations, pocket parks, equipment for public games and activities, planters and furniture in the public realm, and lighting and accessibility upgrades to bring new spaces to life.



Program Goals

- ➔ *Activate public space & streetscapes*
- ➔ *Expand experiential uses*
- ➔ *Beautify high-visibility areas*
- ➔ *Encourage community engagement*



Apply for Fit-Up Funds

Apply between November 15 and December 31, 2023.

Awards announced in early 2024

Access Application Below:

Contact: [Brett Richardson, Freeport Economic Development Corporation](mailto:bbrichardson@freeportmaine.com)



(207) 865-4743 x117



bbrichardson@freeportmaine.com



GUIDELINES

FREEPORT DOWNTOWN MOMENTUM GRANT PROGRAM

OVERVIEW

The Freeport *Downtown Momentum Grant Program* deploys grant funds to empower residents and local organizations to execute high-visibility projects that enhance the experience of residents and visitors and add vitality to the Downtown.

FUNDING & ADMINISTRATION

The *Downtown Momentum Grant Program* leverages Town of Freeport funding allocated for Fiscal Year 2023-2024. The program advances implementation of the *Freeport Downtown Vision Plan*. The Freeport community developed the *Vision* with robust community input during 2021 and 2022. Currently, \$40,000 is available for locally driven projects in publicly accessible areas to advance implementation of the *Vision*.

Momentum is coordinated by the Downtown Vision Task Force in partnership with the Town of Freeport Finance Department. A *Momentum* Committee of the Task Force reviews grant applications and identifies qualified projects to receive grant funds from the program.

PURPOSE

Momentum offers residents the opportunity to help design the future of Downtown Freeport and advance the goals of the *Downtown Vision Plan*. The *Vision* calls on the community to foster a village center that is:

- an inclusive and diverse “Downtown for All.”
- a “New England Village Center” with places to gather for people of all ages.
- a “Walkable and Bikeable” hub that offers safe and accessible pathways for people of all abilities,
- a place to “Embrace the Outdoors” and encourage community gathering and physical activities year-round.
- supports local Arts and Cultural initiatives to attract artists and activate the downtown with events.

GOALS

Momentum provides funding to unleash the creative spirit of Freeport residents and organizations to actively participate in creating the future of Freeport’s Downtown. *Momentum* grants will help to activate and beautify public spaces, provide amenities that encourage residents and visitors to linger Downtown, test new initiatives and offerings in order to gather community feedback, engage local youth, and create opportunities for residents who typically do not participate in Town budgeting processes to help implement the *Downtown Vision Plan*.

PROGRAM GUIDELINES

Available Funding. Funding levels for *Momentum* projects are determined at the discretion of the *Momentum* Committee. Typical *Momentum* projects will be between \$2,500 to \$5,000 in *Momentum* funding. A total of \$40,000 is available.

Application Timeline. *Momentum* grants will be distributed on a quarterly cycle, with an average of \$10,000 available per quarter. The first *Momentum* funding cycle will offer up to \$20,000 total and will include an application period between November 15 and December 31, 2023, with awards announced in early 2024.

Matching Contributions. No matching funds are required but donations and in-kind contributions are encouraged.

Eligibility.

Location & Geography. Freeport's Village Commercial 1 zone.

Qualified Activities. *Momentum* projects must comply with all local regulations and be publicly accessible to all. Projects on private property must be highly visible and accessible to the public.

Eligible projects will advance the goals and spirit of the Downtown Vision, including the following examples:

- Public art installations
- Pocket park development and equipment for all ages to linger.
- Lighting to illuminate and activate public spaces.
- Planters that soften and beautify public spaces and streetscapes.
- Accessibility upgrades for public spaces
- Equipment or space upgrades that encourage physical activities, community interaction, and gatherings.

Disbursement of Funds. The Town will disburse *Momentum* funds for approved projects following the completion and submission of a Downtown Vision Project Charter combined with supporting documentation, including:

For project proposed by a resident. ~ A quote, W9, and proof of insurance from a qualified and licensed contractor who will complete the work. The Town will pay the contractor directly.

For a project proposed by a non-profit organization. ~ A detailed scope of work with itemized costs, a W9, and proof of insurance for all contractors and volunteers who will contribute labor on Town property. The Town will disburse funds to organizations that have insurance and federal tax standing.

If appropriate and beneficial to the completion and administration of a *Momentum* project, the Town will consider serving as a purchasing agent or other reasonable role. Please discuss any administrative support with the Town *Momentum* coordinator (see the bottom of page 3) as you develop your project in advance of applying.

PROJECT REVIEW & SELECTION

Momentum applications will be reviewed by a Town Council-appointed *Momentum* Committee based on a clear project selection criterion informed by goals and priorities identified by the Freeport community in *Downtown Vision Plan*. For projects funded at \$10,000 or less, the Committee awards grants for qualified projects. For projects that exceed \$10,000, the Committee makes recommendations to the Town Council and the Council awards *Momentum* funds.

Grant Committee. The Committee will consist of the Town Manager, one Complete Streets Committee member, two Downtown Task Force members, and one Freeport High School student. The Committee will be staffed by the FEDC Executive Director or alternative member of the Downtown Vision Strategy Team. The *Momentum* Committee reviews projects and awards grants at or below \$10,000 at the Committee's discretion.

Project selection criteria include:

Activates an Underutilized Public Space

Projects that add new vitality, amenities, or experiential offerings in dormant, low-traffic areas are examples that activate underutilized public spaces.

Expands Experiential Use of Public Areas

Projects that illuminate public spaces and expand use to the evening hours, projects that improve accessibility for people of all abilities, and projects that add physical activities or creature comforts that encourage people to linger are examples that expand the use of public areas.

Beautifies Streetscapes and High Visibility Areas

Projects that install public art, planters, and other visual improvements that engage passersby are examples that beautify streetscapes and high visibility areas.

Engages Underrepresented Residents

Projects initiated by or designed for local youth, young adults, and other residents who are underrepresented in Town activities and budgeting processes are examples of projects that engage underrepresented residents.

Project Selection.

The *Momentum* Committee reviews projects and awards grants until funding is exhausted.

The first *Momentum* funding cycle will include an initial application period between November 15 and December 31, 2023, with awards announced in early 2024. Subsequent cycles will occur quarterly until funds are expended.

QUESTIONS?

For assistance with your application, please contact:

Brett Richardson

(207) 865-4743 ext. 117

brichardson@freeportmaine.com